

LOW-PROFILE WIRELESS 8-CHANNEL THERMOCOUPLE MONITOR FOR EXTREME TEMPERATURE ENVIRONMENTS

The ThermoBlade™

- **NEW LOW-PROFILE DESIGN-**
PERFECT FOR LOW CLEARANCE
PROCESS LINES
- Internal thermal insulation will
withstand extreme operating
temperatures (- 328 to 500°F)
- Automatic open thermocouple
detection
- Automatic cold junction compensation
- Automatic low battery detection and
battery life estimation
- Internal over-temperature warning
- Transmits up to 30m (100´)*
(* under optimal environmental conditions)



The ThermoBlade is a full featured, eight (8) channel wireless thermocouple monitor designed for the foodservice industry. When used with DataLink™ software from Magna, the ThermoBlade wirelessly reports and records temperature data from inside ovens, cooling tunnels and freezer lines. Temperature data is available immediately and may be monitored during process steps for real-time analysis and action. The system automatically alerts users to open thermocouples, internal over-temperature and weak battery conditions. Acquired data is easily manipulated using popular Windows™ programs such as Excel®, PowerPoint® and Word®.

Inputs

The ThermoBlade comes with 8 T-type thermocouples of customer specified length and termination. Teflon® protected thermocouple beads are often desirable, but a variety of termination types are available to meet any need, including insertion probes for monitoring internal dough or product temperatures. During initialization the ThermoBlade records the type of thermocouple attached to each channel and will alert users to open or damaged thermocouples.

Sampling Rates

The ThermoBlade can be configured to sample all eight channels at rates

ranging from days to 5 Hz (200 ms intervals).

Communications

Communication with the ThermoBlade is achieved via a proprietary wireless networking protocol operating in the ISM band. Each unit has a unique identifier allowing concurrent use of multiple units as well as multiple measurement networks in the same physical space.

Additional Required Equipment

The ThermoBlade requires the use of:

- 1) GateWay™, wireless network access point
- 2) DataLink™, data acquisition and display software



ThermoBlade Specifications

Thermocouple Inputs-

Number of Channels: 8

Thermocouple Types: T-type standard
Also available: Types E, J, K, N, R & S

Cold Junction Compensation: Automatic

Thermocouple Characteristics:

Type	Range (°C)	Accuracy*	Resolution
T	-270 to 400	± 0.5°C	0.1 °C

*Errors are for the ThermoBlade only and do not include the thermocouple error

Monitoring & Data Recording-

Sampling rate user settable from days to 5 samples /second

All samples time stamped at acquisition
Programmable start time or start on command

Programmable test end time or end on command

Measurements stored or relayed in real-time

General Specifications-

Humidity: 5 to 95% RH non-condensing

Vibration: 10 g (rms 20 Hz to 2000 Hz)

Shock: 3 foot drop

Power: Two AA style batteries

Battery Life: 1.5 yrs at 1 sample/min.

Time Accuracy: ± 1 min / month

Communications Interface†:

ISM band radio (868 / 915 MHz)

†Changes or modifications to the ThermoBlade not approved by Magna Systems may void the user's authority to operate the equipment.

Storage Temperature Range: -40 to 120 °C

Weight:

ThermoBlade only: 150 gm (5.29 oz)
ThermoBiscuit with batteries: 210 gm (7.40 oz)

Thermal Operating Environment-

Maximum Operating Temperature:
260°C / 500°F for up to 15 minutes

Minimum Operating Temperature:
-200°C / -328°F for up to 26 minutes

Continuous operating temperature range:
-40 to 80°C (-40 to 176°F)

Time vs Temperature Curves

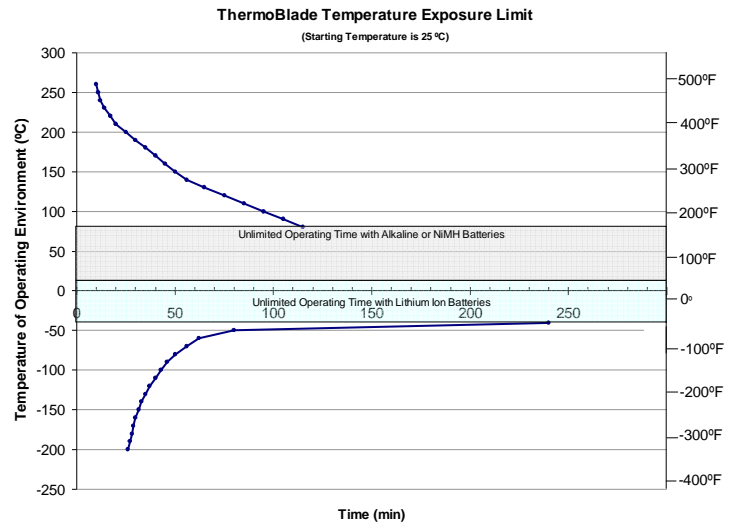

Enclosure: 6063 Aluminum

Dimensions:

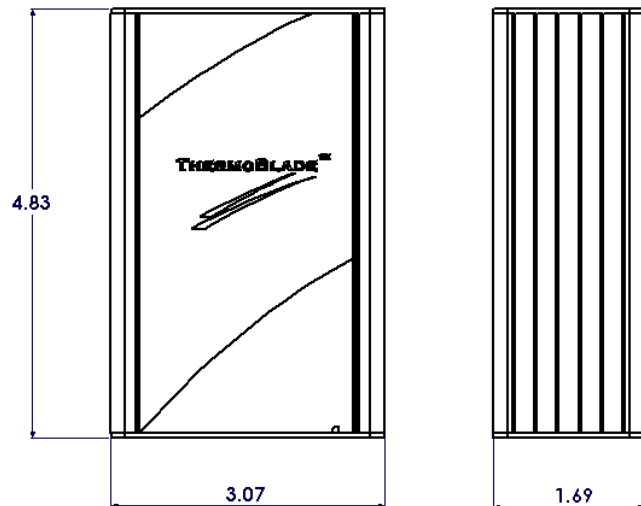

For more information or to order contact us toll-free at 1 888 962-4629



www.kuoridata.com
+1 408 246 4050